

Tool Of The Trade

Using an analog impedance meter

By Pat Brown

One of my favorite field tools is a basic analog impedance meter. It can be used to troubleshoot a host of sound system problems, either stand-alone or with some additional gadgets.

The TOA Electronics ZM-104 has been around for many years. Many experienced audio people have one; mine has served me well and has the scars to prove it. The ZM-104 will serve as the example meter for purposes of our discussion here, although in principle, the following tests can be conducted using any similar device.

Let's have a look at the meter's functions and characteristics, as well as some of the basic tests it can run.

The Device. The ZM-104 is classic looking, with black chassis and analog meter movement. There is an "off" button along with three range switches, a zeroing button and a zeroing potentiometer. (Figure 1)

The analog meter movement is great for finding intermittent problems. There is no "boot up" required and the four AA batteries last for a very long time between charges.

The range switches are used to change the range of the analog display by factors of 10. As with all analog meters, the range setting that produces a mid-scale reading should be used. The zeroing button temporarily shorts the output terminals of the meter together, allowing the zeroing pot to be used to "zero" the meter.

The meter probes can be shorted as an alternative to using the zeroing switch. Note that the meter must be re-zeroed if the range switch is changed. As with all electrical or acoustical measurements, the person doing the measuring ought to make an educated guess about what the reading should be before the measurement is made.

If completely unsure, then start

with the "x1" button and work up to the mid-scale reading.

The meter's output signal is a two-volt peak square wave at 20 milliamps (x1 range).

Note that impedance meters can be used to test components that are switched "on." It is important that the component NOT be passing a signal! So, "powered on" and "no signal present" are important prerequisites for any of the following tests.

NOTE: For all tests, the leads on the ZM-104 can be applied without regard to polarity, although they are shown as red and black in the figures used here.

Impedance. Electrical power sources produce voltage and current. Electrical current between a source and load may flow in one direction only (direct current or DC) or in both directions (alternating current or AC).

Impedance is the opposition to the flow of electrical current. It has two ingredients – resistance and reactance. Only resistance need be considered in a DC circuit. Both resistance and reactance must be considered in an AC circuit.

An ohm meter measures the opposition to DC, which is why it is sometimes called a resistance meter. The meter itself can serve as the current source. In alternating current circuits, another form of opposition is present.

Reactance is the frequency-dependent opposition to the flow of current. It cannot be measured with an ohm meter, because DC flows in only one direction. An impedance meter generates an alternating current, which can be fed to the device-under-test (DUT).

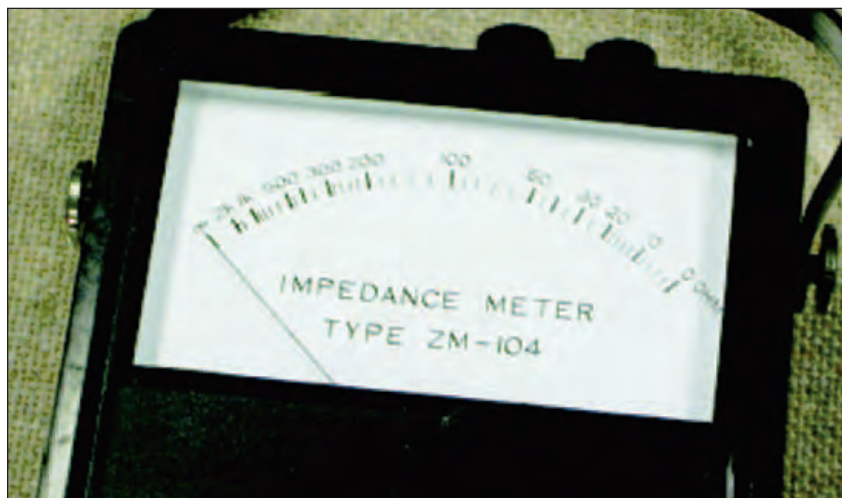

Figure 1: The ZM-104 impedance meter.

Tech Topic

Measuring Impedance. Several methods can be used to determine the impedance of a load. The most straightforward way is to use Ohm's Law to determine impedance from the voltage across the load and the current through it. **Figure 2** shows how to make the measurement with a volt-ohm meter (VOM).

Impedance can also be measured using a constant current source, the method that the ZM-104 uses. The meter has a high output impedance and acts like a constant current source (the current through the load is independent of the load impedance).

The small voltage drop across the load is proportional to the load impedance. This voltage produces the meter deflection on the calibrated scale.

Differential Input Test. Differential inputs have inverting (-) and non-inverting (+) inputs (Pins 2 and 3 on XL connectors). An active differential input can be identified by connecting one lead of the ZM-104 to Pin 1 and the other to the + and -, alternately. Both connections should produce an output signal from the DUT. (**Figure 3**)

Common-Mode Rejection. This one is just like the differential input test, except that instead of driving the + and - terminals alternately, lay the test probe across both. (**Also Figure 3**) The signal will be cancelled by the common-mode rejection ratio (CMRR) of the input if it is differential.

Balanced Output Tester. A balanced output will have the same output

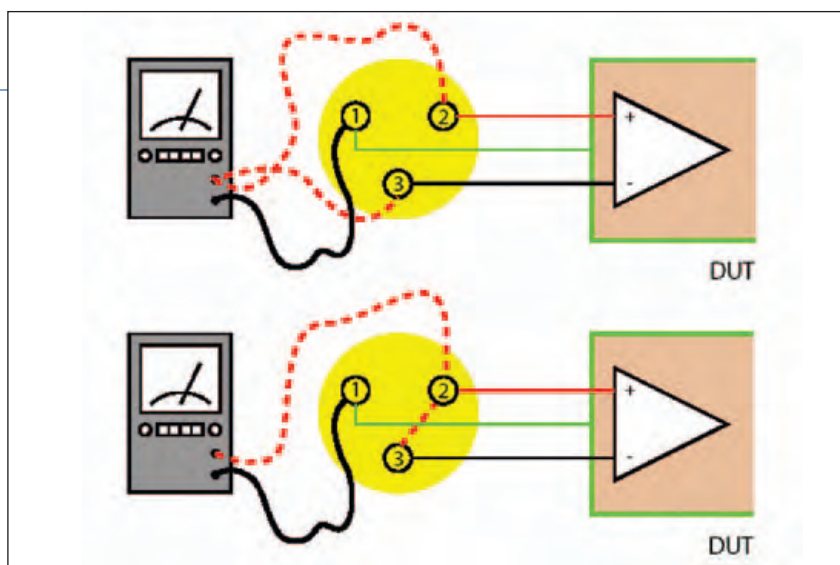

Figure 3: Above, differential input and input impedance test, and below, common-mode rejection test.

impedance from each output leg. Use Pin 1 as common and check the impedance into the plus and minus terminals respectively. The value should be low (typically less than 600 ohms) and within 1 percent of each other.

Continuity Tester. The ZM-104 will tolerate a dead short between its output terminals, so it makes a very good continuity tester. The analog meter movement makes spotting intermittent connections quite easy. I often use this test to verify that all metal panels on an electronic product are at the same (ground) potential. (Don't be afraid to scrape a little paint when doing this test.)

Loudspeaker Wiring Identification. The ZM-104 will produce a distinguished tone from a loudspeaker, without the use of an amplifier. I will often use this to identify pairs in multi-

way loudspeakers. The 1 kHz square wave has enough spectral content to produce some level of output from any loudspeaker component. Horns are easily identified over woofers by the increased loudness and definition of the tone. (**Figure 4**, next page)

Signal Generator. Sometimes it's advantageous to know if a device passes a signal or not. In such cases, the ZM-104 can be connected across an input. The voltage should be sufficient to drive any mixer to "meter zero." Alternately, a "butt set" (**Figure 5**, also next page) can be used across the output of the device to detect the signal.

Transformer Tester. The turns ratio of a transformer can be found by connecting the ZM-104 across the primary and a known resistor value across the secondary. If the measured impedance is the same as the known resistor, then the transformer has a 1:1 turns ratio.

If the impedance is higher than the known resistor, then the transformer is a "step-down" model. If the impedance is lower than the known resistor, the transformer is a "step-up" model.

Wire Pair Identification. The individual pairs in multi-pair "snake" cables can be identified by connecting the ZM-104 to a twisted pair, and then "sniffing" the other end with an inductive tracer. (**Figure 5** inset) These tracers are available at electronics and home supply stores.

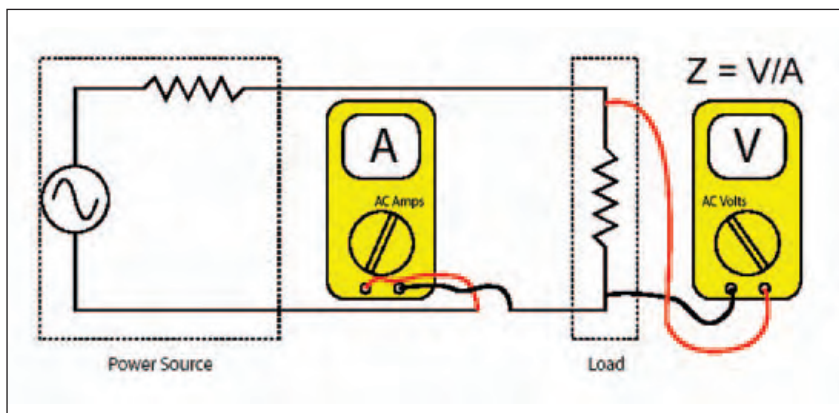

Figure 2: The "manual" method of determining impedance.

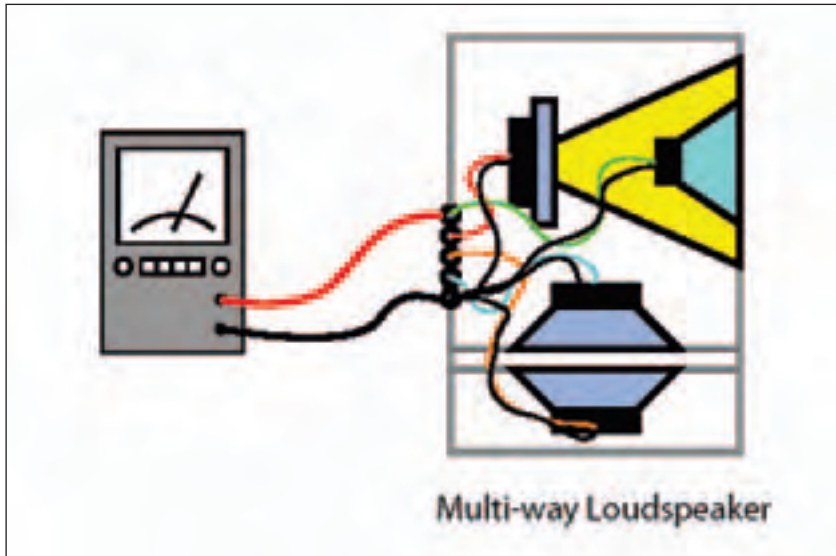

Figure 4: Identifying loudspeaker wiring.



Figure 5: A passive "butt set" increases the usefulness of the ZM-104 (courtesy of www.jwdavis.com). An inductive tester is equally useful (inset).

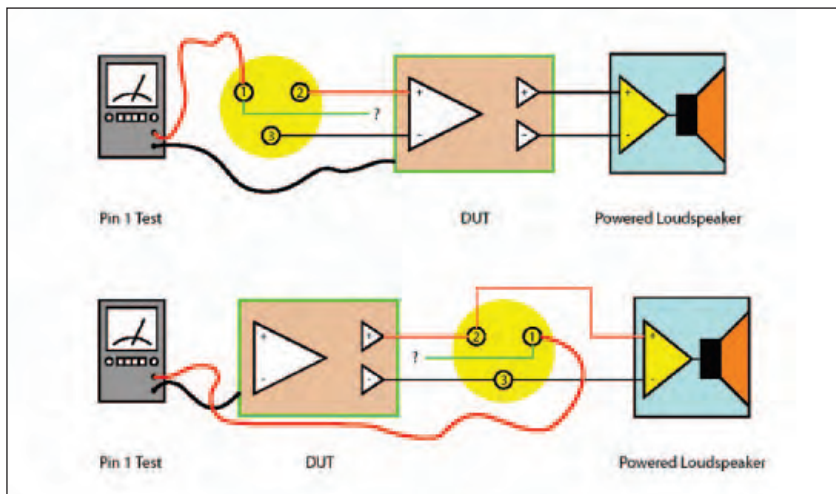

Figure 6: Performing the Pin 1 test on an input (above) and an output (below).

Pin 1 Tester. Many audio products have the internal audio ground connected to Pin 1 of their input and/or output connectors. (Figure 6) This is a bad practice (it causes an audible tone from the unit); the shield of the connecting cable should be lifted or routed directly to the chassis with a jumper.

The ZM-104 sources about 20 milliamp on the x1 setting. This is enough current to identify the problem but not enough to damage any internal components, etc. (For more information, see *AES Journal* reprint, "Grounds And Shields," June 1995.)

Impedance, Part Deux. The 1 kHz of the ZM-104 is great for tone is perfect for checking the impedance of any input or output of an electronic audio component.

Keep in mind that loudspeakers have complex impedance curves, but the 1 kHz impedance measurement can at least reveal whether the voice coil has continuity, or whether a loudspeaker line is open or shorted. These are by far the most common fault conditions for installed and portable loudspeakers.

If you need to know the minimum impedance of a loudspeaker (this is usually the parameter of interest when loading amplifiers and selecting cable) then use an ohm meter across the loudspeaker's terminals. This will measure the DC resistance of the transducer, which is typically the low spot on an impedance curve.

Note that transformers and capacitors will not pass DC, so if you need to know the impedance of such devices you can simply measure the current with a known voltage applied and calculate it using Ohm's Law. (Again, Figure 1)

In the age of computers, DSP and wireless communications, don't overlook the time-proven fundamental tools of our trade. The mark of a good audio technician isn't having the latest gear – it's knowing how to get the answer with the tools that are available. ■

Pat and Brenda Brown own and operate Syn-Aud-Con, conducting training seminars around the world. For more info go to www.synaudcon.com.